

RSB Rotation Stage

UHV Rotation Stage

Ultra-high vacuum compatible rotation stages intended for intermittent rotation of balanced loads or as a precision gearbox.

Manufactured with UHV compatible material and construction methods and featuring a preloaded worm drive for zero backlash, continuous rotation range and AML D35.1 UHV stepper motors.

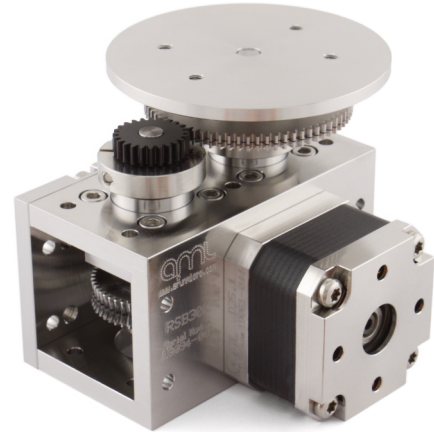

SPECIFICATIONS

Model	RSB10K	RSB20K	RSB30K	RSB90K
Resolution range	360°			
Resolution in full steps	0.036°	0.018°	0.012°	0.004°
Steps per revolution	10,000	20,000	30,000	90,000
Maximum loaded speed	1 kHz 1 sec/rev	1 kHz 20 sec/rev	1 kHz 30 sec/rev	2 kHz 45 sec/rev
Centred load capacity (Normal)	1 kg			
Backlash (Unloaded)	0.04°			
Vacuum	1 x 10 ⁻¹⁰			
Maximum temperature	200 °C			
Motor	D35.1			
Mass including motor	640 g	710 g	710 g	940 g

As standard CRS rotational stages are supplied lubricated with Nyetorr® 6300 low-vapour pressure (6 x 10⁻¹² mbar) grease. Dry lubrication with molybdenum disulfide is available as an alternative option but this will reduce the expected life of the worm wheel.

DIMENSIONS

RSB10K

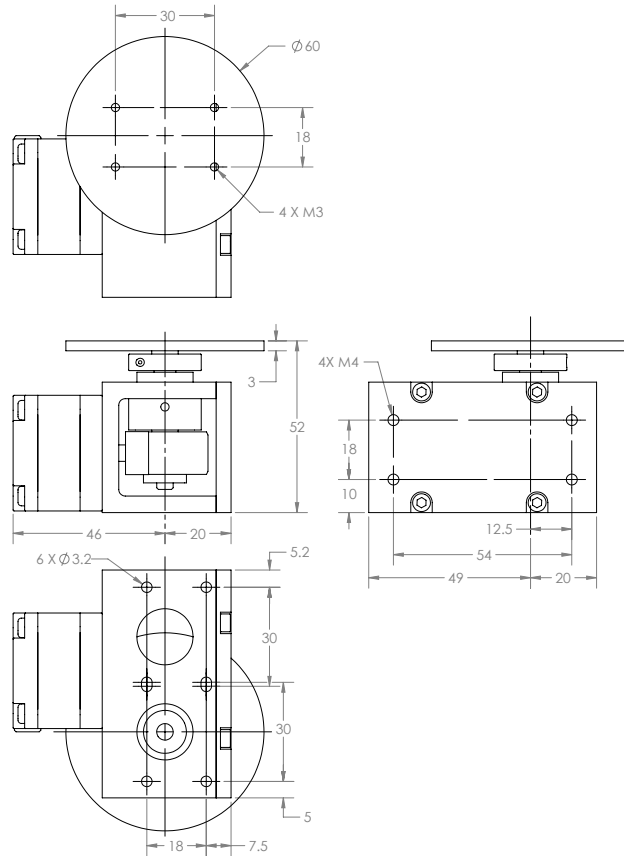

RSB20K / 30K

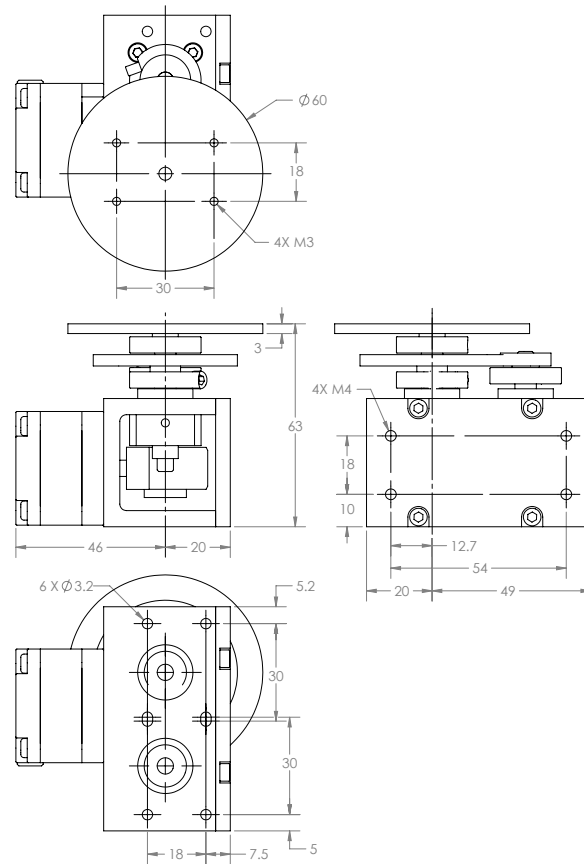

RSB90K

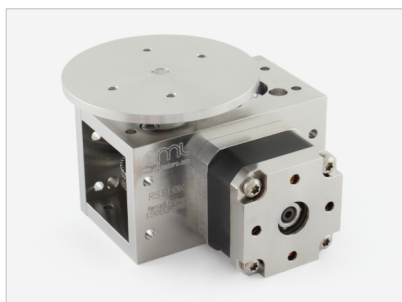
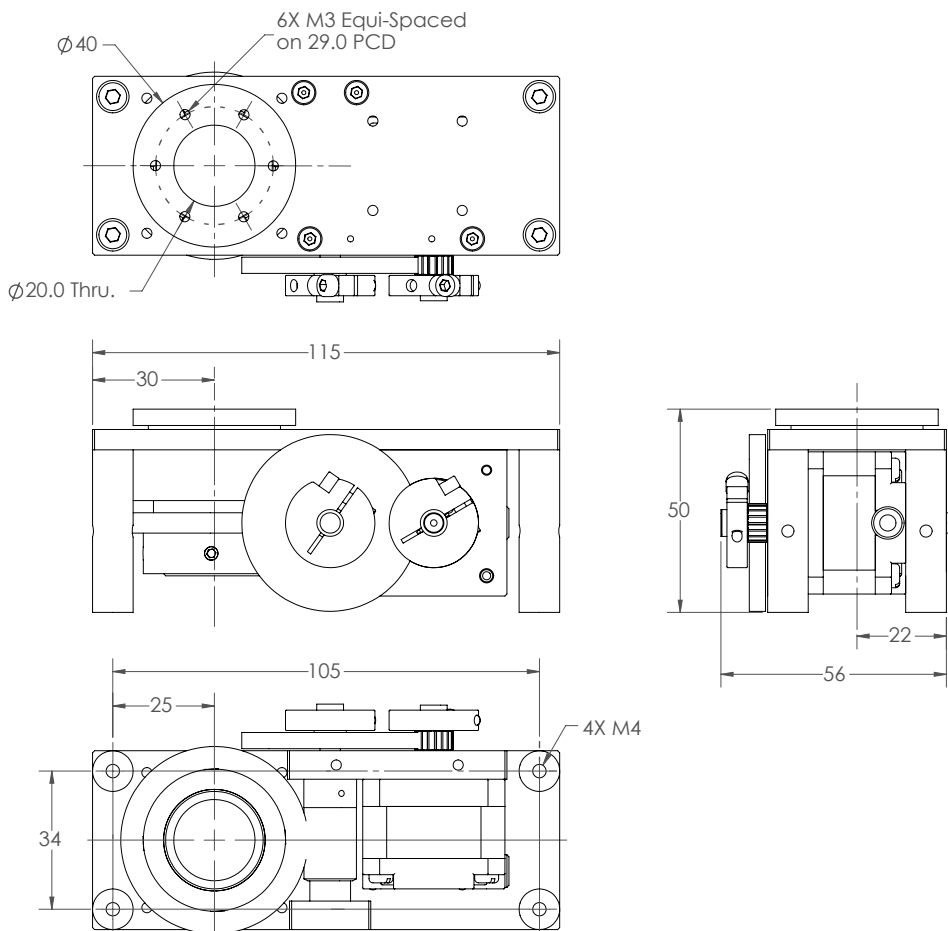

RSB10K



RSB20K/30K



RSB90K

ORDERING INFORMATION

Order Code	
RSB10K	0.036° Resolution Rotation stage
RSB20K	0.018° Resolution Rotation stage
RSB30K	0.012° Resolution Rotation stage
RSB90K	0.004° Resolution Rotation stage

Related Products	
SMD210	Stepper Motor Drive
MLF18F	18-way Electrical Feedthrough
MLF18NBL	3 metre lead, SMD210 to MLF18F
LTVL-xxx	Translation Stage, 5 μ m (xxx = travel in mm)



Arun Microelectronics Ltd.
 Unit 2, Bury Mill Farm
 Bury Gate
 PULBOROUGH
 RH20 1NN
 United Kingdom

Tel: +44 (0)1903 884141
 Email: sales@arunmicro.com

AML pursues a policy of continuous improvement and reserves the right to make detail changes to specifications without consultation. E and OE.