

# Overview of "Rotator Series" Piezoelectric Motion Unit

Low Temperature · Piezoelectric Motion - Rotator Series

Choose your suitable MultiFields® "Rotator Series" product



Rotator16

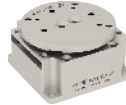

Rotator25



Rotator25-optic



Rotator35

Series defined by size	"16mm Series"	"25mm Series"	"25mm Series"	"35mm Series"	Series defined by size
1 Work Environment	<ul style="list-style-type: none"> <li>• Default: 1.4 K ~ 400 K; 1e-7 mbar; 35 Tesla</li> <li>• Option1 - .ULT, lowest use temperature 30 mK;</li> <li>• Option2 - .UHV, highest vacuum environment 2E-11 mbar;</li> </ul>				Work Environment 1
2 Dimensions	Dia 16*15.6 mm	25*25*16.5 mm	30*23*14.5 mm	35*35*16.5 mm	Dimensions 2
3 Travel Range	360 ° endless				Travel Range 3
4 Max. Load	100 g	250 g	250 g	500 g	Max. Load 4
5 Dynamic Torque	0.4 Ncm	1.5 Ncm	1.5 Ncm	2.5 Ncm	Dynamic Torque 5
6 Max. Velocity @300 K	10 °/s	3 °/s	3 °/s	10 °/s	Max. Velocity @300 K 6
7 Encoder	Resistive Sensor				Encoder 7
Sensor Range	270 °	320 °	320 °		Sensor Range
Sensor Resolution	10 m°				Sensor Resolution
Sensor Repeatability	50 m°				Sensor Repeatability
8 Fine Tune Resolution @ 2 K*	5 μ°	4 μ°	4 μ°	3 μ°	Fine Tune Resolution @ 2 K* 8
9 Step Size (min) @ 300 K*	0.5 m°	0.4 m°	0.4 m°	0.3 m°	Step Size (min) @ 300 K* 9
10 Pins	Drive - 2 pins Sensor - 3 pins				Pins 10
11 Main Body	Default: Pure Ti ULT: BeCu				Main Body 11
12 Weight	10 g	24 g	24 g	45 g	Weight 12

**Fine Tune Resolution @2 K**—Fine tune mode is a unique analog motion driven method, where piezo units are controlled by analog voltage signal, instead of continuous high frequency wave sequence. Because the resolution of the analog signal is very high, the stage can achieve sub-nano meter positioning accuracy.

**Step Size (min) @300 K**—The open loop minimum incremental step size that the stage can move when it's doing stick-slip motion, driven by continuous high frequency wave sequence.

Piezoelectric Motion - LT

Piezoelectric Motion - LT

# "16mm Series" – Rotator16 (closed-loop)

Low Temperature · Piezoelectric Motion- Rotator Series

Smallest rotary stage with closed-loop control



Rotator16.HV

## Features

- Compact design, dimensions: Dia 16\*15.6 mm
- Ultra-high vacuum & very low temperature compatible: 2 E-11 mbar & 30 mK
- Non-magnetic material Composed of pure Ti & BeCu, compatible with the 35 Tesla magnetic field
- High loads & high torque: 100 g & 0.4 Ncm
- Travel range: 360 ° endless
- Closed-loop control with position sensing up to 10 m° resolution

## Dimension drawing



## Rotator16, Specification

\*All data below is measured with 50 ohm wires. Though there is no requirement on wires' conductance, we recommend resistance below 50 ohm.

Optional Versions ⇄		.HV (default)	.ULT	.UHV	.ULT.UHV
		.HV version, default product; .ULT version, used at He3 or dilution cryogenics systems .UHV version, compatible with 2E-11 mbar			
1	Footprint × height	Dia 16 mm × 15.6 mm			
2	Weight	10 g			
Working Environment					
3	Work environment	Temperature range: 1.4 ~ 400 K Vacuum: 1e-7 mbar Max. Magnetic field: 35 Tesla			
4	Option1 - 30 mK		✓		✓
5	Option2 - 2e-11 mbar			✓	✓
Materials					
6	Mainbody	Pure Ti	BeCu	Pure Ti	BeCu
7	Wires	Phosphor Bronze Twisted Paired Wires, 20cm			
8	Pin materials	Polyster (glass fiber filled), BeCu		Peek, BeCu	
9	Pins number	Drive - 2 pins, Sensor - 3 pins			
Open Loop Movement - Single Step Mode & Fine Tune					
10	Fine Tune Resolution @2 K*	5 μ°			
11	Step Size (min) @300 K*	0.5 m°			
Motion ( Closed Loop Mode )					
12	Travel range	360 ° endless			
13	Max. Velocity @300 K	~ 10 °/s			
14	Max. Load	100 g			
15	Dynamic torque	0.4 Ncm			
Position Sensor (Closed Loop Mode)					
16	Position encoder	Resistive Sensor			
17	Encoder range	270 °			
18	Sensor resolution	10 m°			
19	Repeatability	~ 50 m°			

**Fine Tune Resolution @2 K**—Fine tune mode is a unique analog motion driven method, where piezo units are controlled by analog voltage signal, instead of continuous high frequency wave sequence. Because the resolution of the analog signal is very high, the stage can achieve sub-nano meter positioning accuracy.

**Step Size (min) @300 K**—The open loop minimum incremental step size that the stage can move when it's doing stick-slip motion, driven by continuous high frequency wave sequence.

Piezoelectric Motion - LT

Piezoelectric Motion - LT

# "25mm Series" – Rotator25 (closed-loop)

Low Temperature · Piezoelectric Motion- Rotator Series

## Rotary stage with closed-loop control



Rotator25.HV

### Features

- Compact design, dimensions: 25\*25\*14.5 mm
- Ultra-high vacuum & very low temperature compatible: 2 E-11 mbar & 30 mK
- Non-magnetic material Composed of pure Ti & BeCu, compatible with the 35 Tesla magnetic field
- High loads & high torque: 250 g & 1.5 Ncm
- Travel range: 360 ° endless
- Closed-loop control with position sensing up to 10 m° resolution

### Dimension drawing

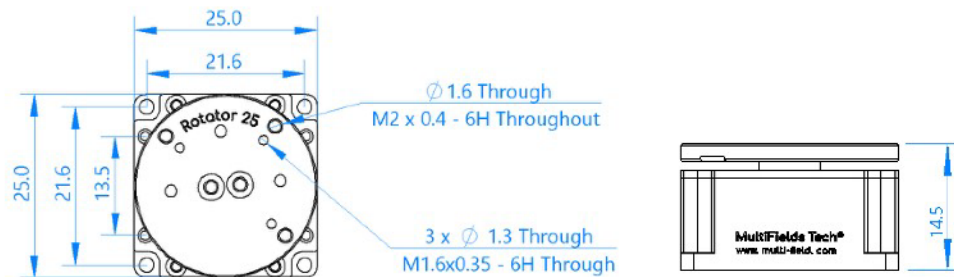

## Rotator25, Specification

\*All data below is measured with 50 ohm wires. Though there is no requirement on wires' conductance, we recommend resistance below 50 ohm.

Optional Versions ⇄		.HV (default)	.ULT	.UHV	.ULT.UHV
		.HV version, default product; .ULT version, used at He3 or dilution cryogenics systems .UHV version, compatible with 2E-11 mbar			
1	Footprint × height	25 mm × 25 mm × 14.5 mm			
2	Weight	24 g			
Working Environment					
3	Work environment	Temperature range: 1.4 ~ 400 K Vacuum: 1e-7 mbar Max. Magnetic field: 35 Tesla			
4	Option1 - 30 mK		✓		✓
5	Option2 - 2e-11 mbar			✓	✓
Materials					
6	Mainbody	Pure Ti	BeCu	Pure Ti	BeCu
7	Wires	Phosphor Bronze Twisted Paired Wires, 20cm			
8	Pin materials	Polyster (glass fiber filled), BeCu		Peek, BeCu	
9	Pins number	Drive - 2 pins, Sensor - 3 pins			
Open Loop Movement - Single Step Mode & Fine Tune					
10	Fine Tune Resolution @2 K*	4 μ°			
11	Step Size (min) @300 K*	0.4 m°			
Motion ( Closed Loop Mode )					
12	Travel range	360 ° endless			
13	Max. Velocity @300 K	~ 3 °/s			
14	Max. Load	250 g			
15	Dynamic torque	1.5 Ncm			
Position Sensor (Closed Loop Mode)					
16	Position encoder	Resistive Sensor			
17	Encoder range	320 °			
18	Sensor resolution	10 m°			
19	Repeatability	~ 50 m°			

**Fine Tune Resolution @2 K**—Fine tune mode is a unique analog motion driven method, where piezo units are controlled by analog voltage signal, instead of continuous high frequency wave sequence. Because the resolution of the analog signal is very high, the stage can achieve sub-nano meter positioning accuracy.

**Step Size (min) @300 K**—The open loop minimum incremental step size that the stage can move when it's doing stick-slip motion, driven by continuous high frequency wave sequence.

Piezoelectric Motion - LT

Piezoelectric Motion - LT

# "25mm Series" – Rotator25-optic (closed-loop)

Low Temperature · Piezoelectric Motion- Rotator Series

Optic optimized design - with 6 mm diameter throughout aperture along rotation axis.



Rotator25-optic.HV

## Features

- Compact design, dimensions: 30\*23\*14.5 mm
- Ultra-high vacuum & very low temperature compatible: 2 E-11 mbar & 30 mK
- Non-magnetic material Composed of pure Ti & BeCu, compatible with the 35 Tesla magnetic field
- High loads & high torque: 250 g & 1.5 Ncm
- Travel range: 360 ° endless
- Closed-loop control with position sensing up to 10 m° resolution
- Aperture  $\Phi$  6 mm

## Dimension drawing

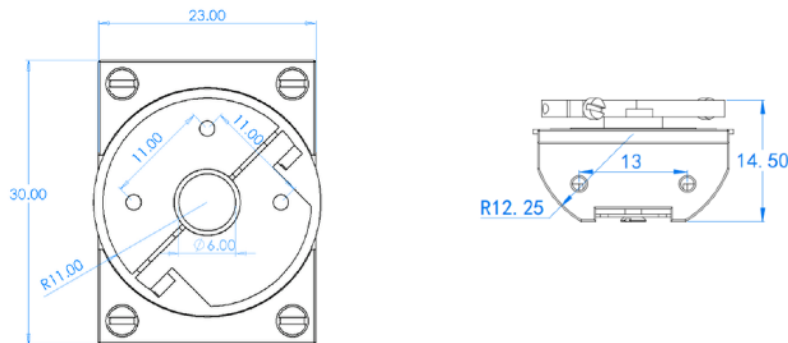

## Rotator25-optic, Specification

\*All data below is measured with 50 ohm wires. Though there is no requirement on wires' conductance, we recommend resistance below 50 ohm.

Optional Versions ⇨	.HV (default)	.ULT	.UHV	.ULT.UHV	
.HV version, default product; .ULT version, used at He3 or dilution cryogenics systems .UHV version, compatible with 2E-11 mbar					
1	Footprint × height	30 mm × 23 mm × 14.5 mm			
2	Weight	24 g			
Working Environment					
3	Work environment	Temperature range: 1.4 ~ 400 K Vacuum: 1e-7 mbar Max. Magnetic field: 35 Tesla			
4	Option1 - 30 mK	✓		✓	
5	Option2 - 2e-11 mbar		✓	✓	
Materials					
6	Mainbody	Pure Ti	BeCu	Pure Ti	BeCu
7	Wires	Phosphor Bronze Twisted Paired Wires, 20cm			
8	Pin materials	Polyster (glass fiber filled), BeCu		Peek, BeCu	
9	Pins number	Drive - 2 pins, Sensor - 3 pins			
Open Loop Movement - Single Step Mode & Fine Tune					
10	Fine Tune Resolution @2 K*	4 μ°			
11	Step Size (min) @300 K*	0.4 m°			
Motion ( Closed Loop Mode )					
12	Travel range	360 ° endless			
13	Max. Velocity @300 K	~ 3 °/s			
14	Max. Load	250 g			
15	Dynamic torque	1.5 Ncm			
Position Sensor (Closed Loop Mode)					
16	Position encoder	Resistive Sensor			
17	Encoder range	320 °			
18	Sensor resolution	10 m°			
19	Repeatability	~ 50 m°			

**Fine Tune Resolution @2 K**—Fine tune mode is a unique analog motion driven method, where piezo units are controlled by analog voltage signal, instead of continuous high frequency wave sequence. Because the resolution of the analog signal is very high, the stage can achieve sub-nano meter positioning accuracy.

**Step Size (min) @300 K**—The open loop minimum incremental step size that the stage can move when it's doing stick-slip motion, driven by continuous high frequency wave sequence.

# "35mm Series" – Rotator35 (closed-loop)

Low Temperature · Piezoelectric Motion- Rotator Series

## Rotary stage with closed-loop control



Rotator35.HV

### Features

- Compact design, dimensions: 35\*35\*16.5 mm
- Ultra-high vacuum & very low temperature compatible: 2 E-11 mbar & 30 mK
- Non-magnetic material Composed of pure Ti & BeCu, compatible with the 35 Tesla magnetic field
- High loads & high torque: 500 g & 2.5 Ncm
- Travel range: 360 ° endless
- Closed-loop control with position sensing up to 10 m° resolution

### Dimension drawing

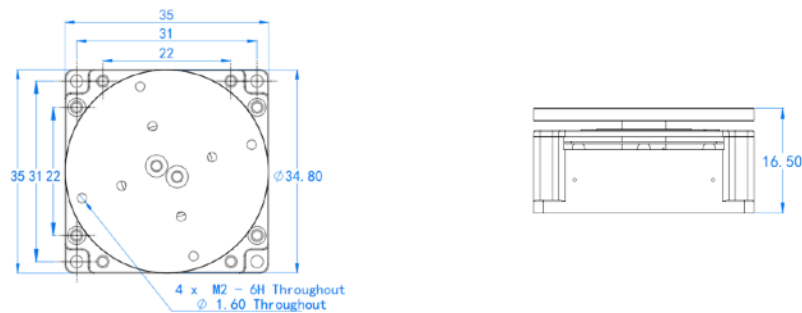

## Rotator35, Specification

\*All data below is measured with 50 ohm wires. Though there is no requirement on wires' conductance, we recommend resistance below 50 ohm.

Optional Versions ⇨	.HV (default)	.ULT	.UHV	.ULT.UHV	
.HV version, default product; .ULT version, used at He3 or dilution cryogenics systems .UHV version, compatible with 2E-11 mbar					
1	Footprint × height 35 mm × 35 mm × 16.5 mm				
2	Weight 45 g				
Working Environment					
3	Work environment Temperature range: 1.4 ~ 400 K Vacuum: 1e-7 mbar Max. Magnetic field: 35 Tesla				
4	Option1 - 30 mK	✓		✓	
5	Option2 - 2e-11 mbar		✓	✓	
Materials					
6	Mainbody	Pure Ti	BeCu	Pure Ti	BeCu
7	Wires	Phosphor Bronze Twisted Paired Wires, 20cm			
8	Pin materials	Polyster (glass fiber filled), BeCu		Peek, BeCu	
9	Pins number	Drive - 2 pins, Sensor - 3 pins			
Open Loop Movement - Single Step Mode & Fine Tune					
10	Fine Tune Resolution @2 K*	3 μ°			
11	Step Size (min) @300 K*	0.3 m°			
Motion ( Closed Loop Mode )					
12	Travel range	360 ° endless			
13	Max. Velocity @300 K	~ 10 °/s			
14	Max. Load	500 g			
15	Dynamic torque	2.5 Ncm			
Position Sensor (Closed Loop Mode)					
16	Position encoder	Resistive Sensor			
17	Encoder range	320 °			
18	Sensor resolution	10 m°			
19	Repeatability	~ 50 m°			

**Fine Tune Resolution @2 K**—Fine tune mode is a unique analog motion driven method, where piezo units are controlled by analog voltage signal, instead of continuous high frequency wave sequence. Because the resolution of the analog signal is very high, the stage can achieve sub-nano meter positioning accuracy.

**Step Size (min) @300 K**—The open loop minimum incremental step size that the stage can move when it's doing stick-slip motion, driven by continuous high frequency wave sequence.

Piezoelectric Motion - LT

Piezoelectric Motion - LT